

PVC-U System

PatioMaster Sliding Door

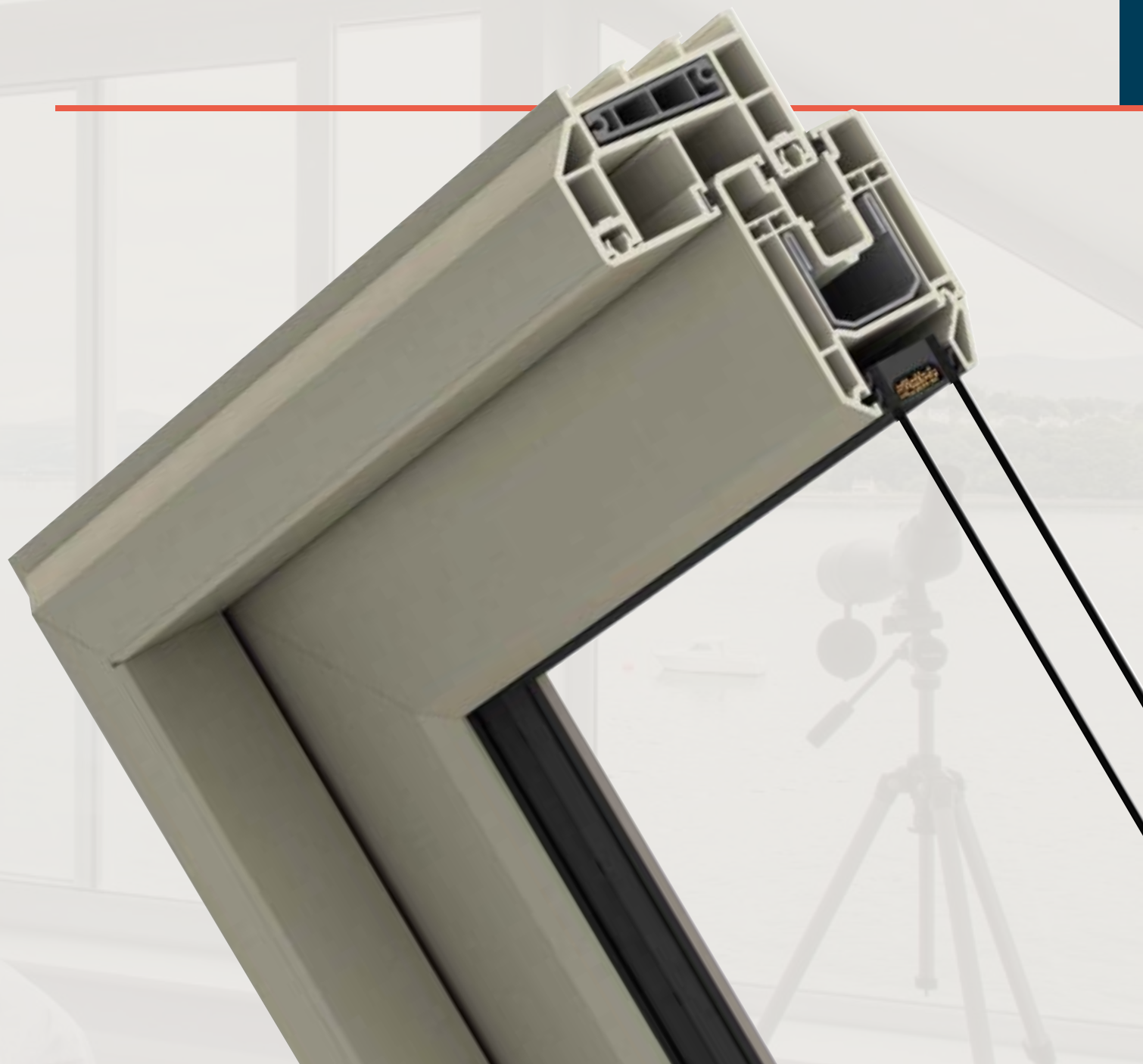

EpwinTM
window systems

The most advanced PVC-U sliding door system on the market

The market-leading PatioMaster Sliding Door System from Epwin Window Systems combines the best in PVC-U aesthetics to deliver a robust, high performing door that fits beautifully into any home.

It now has enhanced aesthetics with an improved interlock sightline and a new midrail design that is easier to fabricate and uses fewer components. There is also improved weather performance and a new option for triple glazing.

Thermal and weather performance have been upgraded with a new sash that increases glazing options to include 28mm and 36mm (triple glazed), while a new PCE gasket design enhances the weather seals for superior performance.

Strength and security have been improved throughout the system. A new, larger reinforcing chamber has made the system stronger. And in response to customer feedback, we have reinstated the homeowner-favourite Yale 6-hook lock. We have also taken security to the next level with additional shootbolt-type locking points to the Yale lock, delivering a 10-point locking upgrade.

The new PatioMaster Sliding Door System includes everything that made it the market leader. But thanks to our commitment to continuous development and innovation, it just got even better.





A truly British heritage

The PatioMaster Sliding Door System is produced by Epwin Window Systems, the UK's largest systems house with a track record stretching back almost 50 years.

We offer the widest portfolio of fully integrated window and door systems, a choice of leading brands, with unrivalled expertise and support to grow your business.

We firmly believe in continuous investment in our production facilities and operations. Our approach means we are able to provide the levels of quality and reliability you have a right to expect.

Our products are designed and manufactured in Britain for the British market. We are active in trade and industry bodies and we take a leading stance in environmental initiatives. Our commitments mean you are able to rely on us to be a proactive partner that adds value to your business.

Because when you work with Epwin Window Systems you get more options and more possibilities.

**MADE IN
BRITAIN** 

Attention to detail as standard

The PatioMaster Sliding Door System is the UK's most popular sliding door system for many reasons. Here are just a few of them.



Aesthetics

- 70mm system compatible with all leading PVC-U systems
- Chamfered profile fits beautifully into British homes
- 2, 3, 4 or 6-pane configurations
- Maximum brickwork opening up to 5.9 metres with Triple Track option
- Choice of handles and finishes, including dual colours
- Full range of colours and finishes, including grained and flat textures
- Patented interlock system with enhanced sightlines
- NEW mechanically jointed midrail design offers enhanced appearance.



Strength and Security

- Homeowner-favourite Yale 6-hook locking system
- Additional shootbolt extensions to deliver 10-point locking that meets the requirements of PAS 24
- IMPROVED reinforcing chamber width delivers a system that's stronger and significantly enhances weather performance.



Performance

- 28mm and 36mm (triple glazed) glazing options
- NEW PCE gasket design delivers improved weather seals
- Larger sash reinforcing enhances meeting stile strength for improved wind loading.



Ease of Installation

- Glazing rebate increased from 17.5mm to 20mm to improve ease of glazing
- Additional clearance around the lock case for reinforcement
- NEW sash profile with dedicated fluted screw chamber to enhance screw retention and eliminate the need for RCM to achieve PAS 24
- Interlock fixes directly into the profile with threads that pick up along the channel
- Full range of ancillary products including cills, add-ons and couplers.

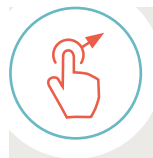

Usability

- Easy glide, stainless steel track system for maximum structural integrity, corrosion resistance and service life
- Edge-located rollers for easy adjustment and smooth glide feel
- Beautiful, easy-to-use handles.



PatioMaster Twin Track Sliding Door System

The PatioMaster Twin Track Sliding Door is a classic sliding door system.

Simple good looks, ease of use and impressive energy efficiency and security credentials all add up to a sliding door system that adds value in more ways than one.



Product features

- 2, 3 or 4-pane configurations
- 28mm and 36mm glazing options
- U-value 1.0 W/m²K with triple glazing
- Easy glide, stainless steel track system
- Low sightline co-extruded gaskets
- 10-year guarantee

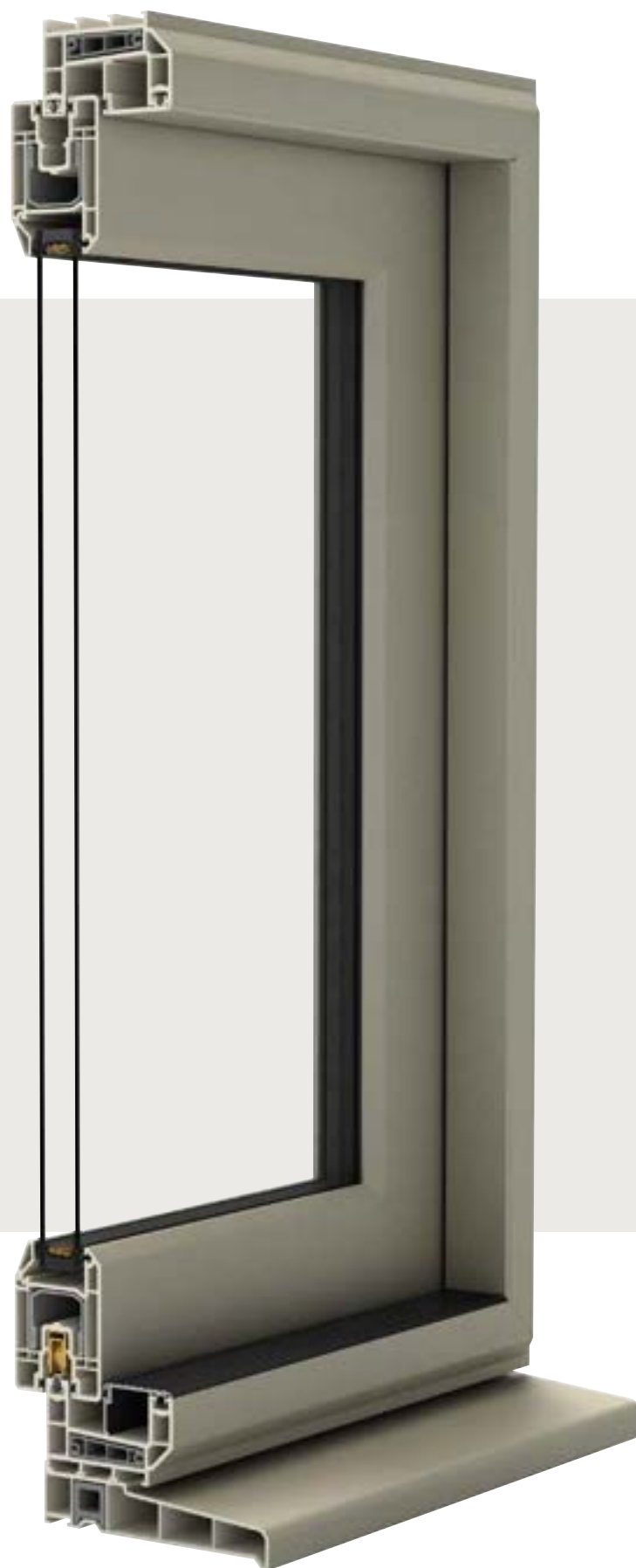

PatioMaster Triple Track Sliding Door System

The Triple-Track Sliding Door is a stunning glazing solution that delivers the wide-open feel that today's homeowners love, even at smaller frame sizes.

With two or four sliding sashes that stack neatly behind each other, they don't encroach on precious space indoors or out. They offer significantly more open space compared to conventional sliding doors – and they have a better glass-to-frame ratio than doors with folding sashes for bigger, more expansive sightlines.



Features

- 3 or 6-pane configurations up to 5.9m brickwork opening
- 28mm and 36mm glazing options
- U-values as low as 1.0 W/m²K with triple glazing
- Maximum size with a 6-pane doorset: 5920 x 2360
- Increases available opening space
- Carriage wheels at sash ends for easy adjustment and stability
- Low sightline co-extruded gaskets
- 10-year guarantee



Ancillaries

A useful range of ancillaries.

As an Epwin Window Systems product, PatioMaster Sliding Doors have the largest range of ancillaries on the market so you can achieve a perfectly fitting project every time. Not only that, every item in the range works across all our systems. It means you can reduce stockholding and extend versatility.

Cills

Cills are available from 85mm to 225mm and include steel and recycled composite options. They all use a single reinforcing size to help reduce stockholding.

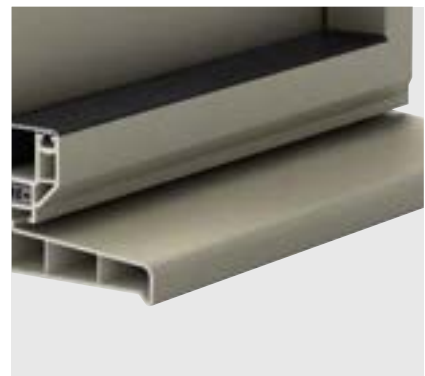

Thermal Inserts

Made using recycled material, Epwin Window Systems thermal inserts can help to achieve better U-values and DSER's without the cost of the most highly insulating sealed units. They are added to the outerframe during fabrication and effectively increase the number of insulating chambers in the profiles.



Midrails

At 120mm deep, the newly-designed PatioMaster midrail is aesthetically appealing and easier to fabricate.

Packers

Packers are available in four sizes from 15mm, 20mm, 35mm and 50mm.



A colourful entrance

Epwin Window Systems leads the way with colour to help you make the most of the market opportunities on offer.

The PatioMaster colour range includes modern classics like Anthracite Grey and timeless shades such as Claystone. Dual colour options allow for different interior and exterior finishes.

Complementary base colours of white, grey, brown, tan and cream deliver next-level aesthetics as standard.

The UK's most popular colours are available directly from stock, making colour an easy up-sell. Plus, our made to order service reduces lead times for custom shades, making colour an option for every project.

It all adds up to a colour offering that sets a new standard.

Stock Colours

White PVC-U Base

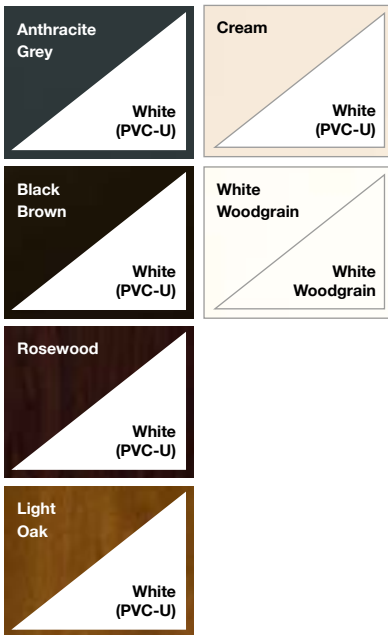

Coloured Base

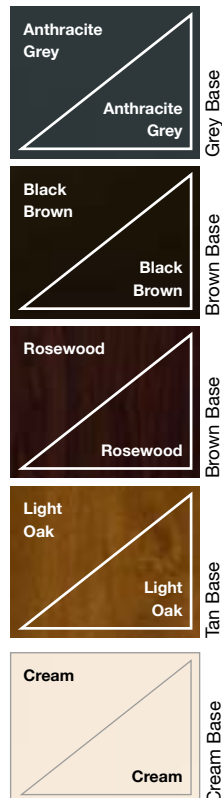

Fast Track Colours

White PVC-U Base

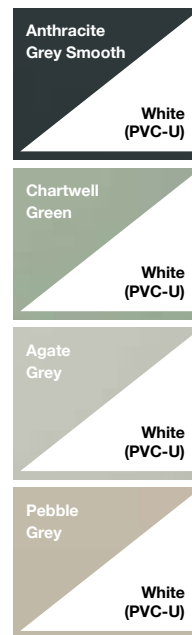

Coloured Base

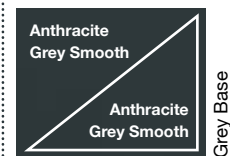

Base Colours

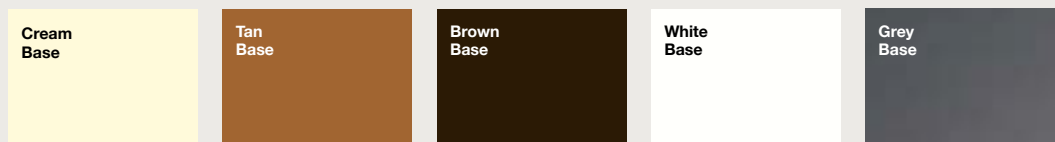



Made to Order Colours

Our made to order colours are available foiled on one side with a white base, foiled on both sides on a complementary base colour or foiled with different colours either side with a choice of any base colour.

Cream Base

Cream
Claystone
Pebble Grey
Windsor
Sage Smooth
Agate Grey
Chartwell Green

Tan Base

Irish Oak
Honey Oak Super-Matt
Light Oak
Pyrite

Brown Base

AnTeak
Swamp Oak
Rosewood
Black Brown
Flemish Gold Smooth

White Base

White Woodgrain
Dark Red
Steel Blue
Dark Green

Grey Base

Black Ultra-Matt	Slate Grey
Silver D Smooth	Anthracite Grey
Hazy Grey Finesse	Anthracite Grey Smooth
Kensington Grey	
Buckingham Grey	
Basalt Grey Smooth	
Slate Grey Finesse	

High quality hardware for high quality doors

PatioMaster locking handles are designed to perfectly enhance the quality and design of PatioMaster Sliding Doors. They are available in a range of colours to complement any colour scheme.



A simple solution

When it comes to sourcing the hardware for PatioMaster Sliding Doors, Epwin Window Systems offers a complete, compatible hardware range.

We are one of the UK's leading suppliers of hardware to the industry and our range includes household name brands and trusted specialists, all renowned for long-term performance and reliability. It's clear evidence of our commitment to supporting fabricators and installers every step of the way.



Accreditations & testing

Industry-leading credentials from an industry-leading door system.



BS EN ISO 9001
BSI Registered firm scheme: Quality Management Systems.



BS EN ISO 14001
Manufactured under an ISO 14001 Registered Environmental Management System.



BS ISO 45001
Occupational Health and Safety Management Systems.



KM 12895
BS EN 12608
PVC-U Profiles for the Fabrication of Windows and Doors

BS EN 12608
PVC-U Profiles for the Fabrication of Windows and Doors.



KM 33523
BS EN 12608 / PAS 24
PVC-U Profile – Enhanced Security Window System Supplier

BS EN 12608/PAS 24
Enhanced Security Window System Supplier.



KM 56791
BS EN 12608 / PAS 24
PVC-U Profiles – Enhanced Security Doors System Supplier

BS EN 12608/PAS 24
Enhanced Security Door System Supplier.



KM 594776
BS 8529 / PAS 24
Enhanced Security Composite Door System Supplier

BS 8529/PAS 24
Enhanced Security Composite Door System Supplier.



Secured by Design
The UK Police initiative supporting the principles of ‘designing out crime’ by use of crime prevention and security standards.



VinylPlus
A labelling scheme to identify the most sustainable and high-performance PVC-U products.

Tested to the highest standards

Every aspect of the Epwin Window Systems offering is continually tested and assessed to ensure it offers excellence in every respect.

All PatioMaster products meet current Building Regulations as standard and many can provide solutions far above these requirements. It means that no matter how demanding your project, PatioMaster delivers.

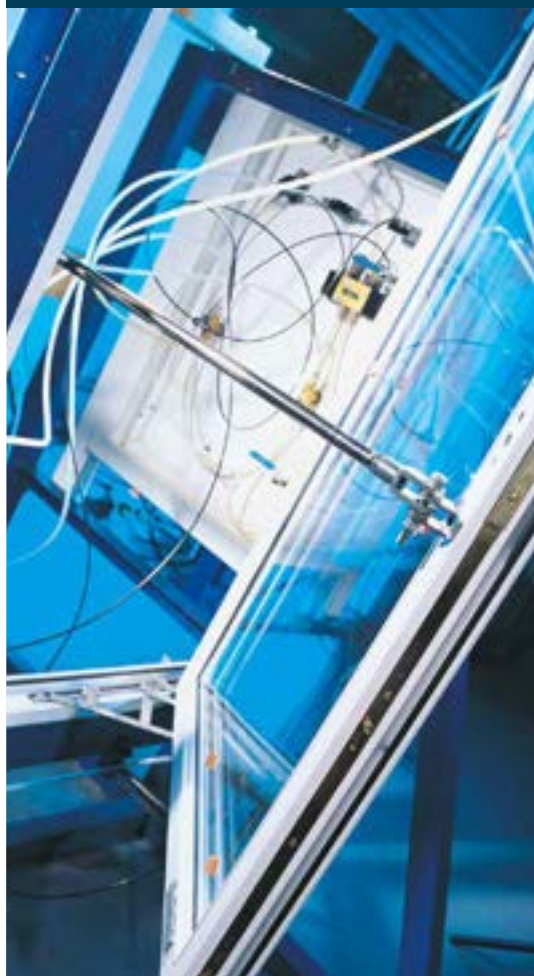

Solid security

All aspects of PatioMaster Sliding Doors have been considered from a security perspective.

They feature a 6-hook locking system by Yale, one of the world's renowned lock manufacturers and a household name. PAS 24 and Secured by Design versions of the door feature a 10-hook lock developed especially for us by Yale.

They have rigid, impact-resistant profiles and steel-reinforced sections for strength.

Toughened glass is used as standard and laminated glass is available for even more protection if required.



Secured by Design



Official Police Security Initiative

Impressive thermal efficiency

The thermal efficiency of doors and windows has never been more important. PatioMaster Sliding Doors more than deliver on the requirements.

PatioMaster Sliding Doors can achieve a U-value of 1.3 W/m²K with double glazing and 1.0 W/m²K with triple glazing and a Doorset Energy Rating of A+.



Sliding Door System Product Data



Sliding Door

PERFORMANCE & ACCREDITATION

U-value (double glazing)	1.3 W/m ² K	
U-value (triple glazing)	1.0 W/m ² K	
Energy Rating (DSER)	A+	
Acoustic Performance-various options depending on specification-RW (C;Ctr)	36 to 44	
Air Tightness (Pa)	Class 2 (300Pa)	
Water Tightness (Pa)	Class 6A (250Pa)	
Wind Loading (Pa)	Class A3 (1200Pa)	Class A4 (1600Pa)
Security	PAS 24	
PAS 24 Sash Size Limits (mm)	W 1198 H 2116	
Secured by Design (SBD)	✓	

CONFIGURATIONS

Horizontally Sliding	✓
2-Pane	✓
3-Pane	✓
4-Pane	✓
Triple Track 3-Pane	✓
Triple Track 6-Pane	✓
Multilight	

SASH WEIGHT & SIZE LIMITS

Sliding Sash	150 kg
2-Pane Doorset (mm)	3000 x 2360
3-Pane Doorset (mm)	4420 x 2360
4-Pane Doorset (mm)	5920 x 2360
6-Pane Doorset (3-Track) (mm)	5920 x 2360
Fixed Light	N/A

SYSTEM FEATURES

System Depth (mm)	70
Dual Colour Option	✓
Multipoint Locking	✓
Glazing Options	Internally Beaded
Glazing Thickness (mm)	28 & 36



For more information about Epwin Window Systems products visit
www.epwinwindowssystems.co.uk



Epwin[™]
window systems

Epwin Window Systems is a manufacturer of PVC-U and aluminium profile systems, supplied to independent manufacturers and installers who contract to install windows, doors and conservatories. Epwin Window Systems cannot be held accountable for manufacture or installation by independent companies. All information in this publication is provided for guidance only and is given in good faith. As it is company policy to continually improve products, methods and materials, changes of specification may be made from time to time without prior notice. This statement does not affect your statutory rights. © Epwin Window Systems. Part of the Epwin Group Plc. EWS18520